

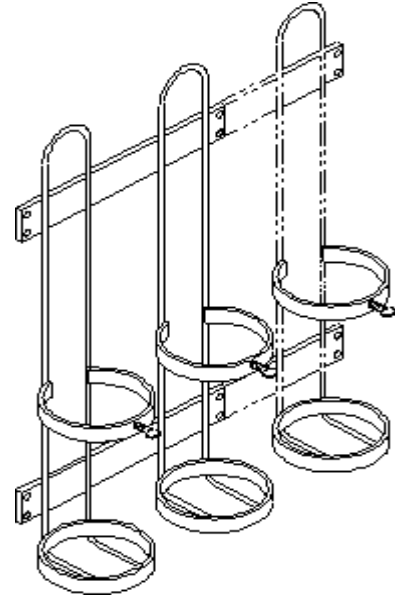

SECURITY

RESISTANCE

EFFICIENCY



Total control at all times

SPECIFICATIONS

Height: 28"

Width: 5"

Chromed MD Q

Interior dimensions: 4.5"

2 Plates: 1' x 2-1/8" x 1-8/7

POSSIBILITY OF MULTIPLE & CONSECUTIVE EXTENSIONS:

UCD-01 DOUBLE

UCT-01 TRIPLE

PART NUMBER: UC-01, UCD-01, UCT-01

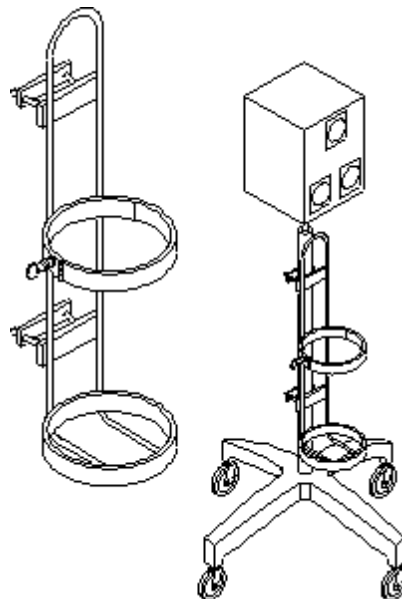

PORTABLE GAS SYSTEM

PART NUMBER: UC-01-S